

APPLICATION OF HOME LIGHT CONTROL SYSTEM USING ARDUINO WITH MOBILE BASED WIFI MEDIA

Uning Lestari¹, Erfanti Fatkhiyah², Andung Febi Prakoso³
Informatic Engineering, Institut Sains & Teknologi
AKPRIND Yogyakarta
Email : erfanti@akprind.ac.id², andungfp@gmail.com³

*Corresponding author
Email :
uning@akprind.ac.id

Abstrac

Nowadays, technology development encourage people to think creatively, not not only to explore new discoveries, but also to maximize existing technological performance to ease human work in everyday life. The need for an automatic control system is needed with the increasing activity of each individual community with various erratic activities and times. As a result, many activities in the household are delayed, such as turning on or turning off the lights in every room at night and in the morning. *Smart home system* is one solution that suits the needs of the current automatic controllers. *Smart home system* is a home or building is equipped with an integrated technology with the help of the tool/tools which can be a computer or other device, for example a smartphone to provide all the comfort, safety, security and energy saving is automatic and programmed. The smart home system can be used to control almost all equipment and equipment at home, from lighting settings to various household appliances, which can be done only by using sound, infrared light or remote control. In this study, a smart home system was created for home light control system applications using Arduino Uno microcontroller via mobile-based wifi media. With this application the user can control the home lights by turning off or turning on the home lights remotely through the mobile media. Thus the efficiency of electricity use becomes more maintained.

Keyword: Application, Mobile, Arduino, Smart Home

1.0 INTRODUCTION

Nowadays, technology development encourage people to think creatively, not not only to explore new discoveries, but also to maximize existing technological performance to ease human work in everyday life. The need for an automatic control system is needed with the increasing activity of each individual community with various erratic activities and times. As a result, many activities in the household are delayed, such as turning on or turning off the lights in every room at night and in the morning.

Smart home system is one solution that suits the needs of the current automatic controllers. *Smart home system* is a home or building is equipped with an integrated technology with the help of the tool/tools which can be a computer or other device, for example a smartphone to provide all the comfort, safety, security and energy saving is automatic and programmed. The smart home system can be used to control almost all equipment and equipment at home, from lighting settings to various household appliances, which can be done only by using sound, infrared light or remote control. Electronic systems usually consist of electronic data provider devices (sensors), data control interpretation devices (actuators), control devices (central units) and interface communication devices for systems (gateways). All of these devices are usually placed in different locations of the building according to the need to allow simple levels, low data, but strong communication between devices [1].

Electronics is one of the technologies that help human life to become easier. One form of electronic control access system that is currently being developed is a remote control system, allowing one to control an object remotely. It is very useful to support the lives of modern society who need very high mobility. If all the lights in a house are controlled without having to turn on the switch, the role of the microcontroller and Android smartphone is very important to provide comfort and convenience in controlling the home lights. Therefore, in this study a home light control system based on Arduino microcontroller was made using wifi with the help of an Android smartphone. By using this system, people are expected to be able to control the house lights easily without having to turn on the light switch and control the home lights remotely using smartphone media.

The purpose of this study was to make a smart system application system for remote home light controllers using the Arduino system. This system can only be run using wifi based on smartphones with the Android operating system. In this application the controller will be made by sampling using 4 5 Watt lights. Ethernet Shield will be used as a link between the Arduino microcontroller and a smartphone to control the relay. This system is expected to make it easier for everyone to turn on the home lights remotely without using a light switch.

2.0 LITERATURE REVIEW

The rapid development of digital technology has contributed to the development of computer technology. Today, many electrical devices work in an integrated manner with computer systems. One technology that is currently being developed is about Smart Home. Smart Home is a system that can control various kinds of electronic equipment and equipment in a house or building automatically which is controlled through a smartphone or computer. Several studies on Smart Home have been carried out by several previous researchers. Research that makes the application of design of magnetic door locks using keypad and solenoid with Arduino Uno microcontroller [2]. This study aims to make a security in the form of a password code to open and lock a door. This study uses the keypad as an input tool in the form of password codes, solenoid as a tool to open and lock, and has the feature of changing and storing new password codes directly from the keypad without having to reprogram from the computer.

Research on the control of home lights has also been carried out using the Arduino ATmega328 and Android smartphones. In this study using the Bluetooth HC-06 module which serves to connect between relays on the microcontroller with an Android smartphone in order to control the flame of each lamp [3]. Research on making systems that can control electricity in a room. The system is designed by utilizing the ATmega328 microcontroller optimally by combining several components such as Relay and the GSM/GPRS SIM 800L Module. GSM/GPRS Module 800L SIM is a component that functions as an SMS gateway. In this system the light control is run by using the help of a smartphone. This system uses sending an SMS to control each lamp. So that by typing an SMS alone can run this system [4]

In addition, other studies on systems that can control a lamp by using a vibration sensor has been produced. This system consists of several components such as ATmega328 microcontroller and vibration sensor. This system works if someone does a missed call to the mobile server then vibrates, and the vibration sensor reads the vibration wave, then the vibration will be processed to Arduino, the relay will be active and then control the lamp. If the vibration is read 3 times, the relay will control the lights on. Conversely, if the vibration is read 6 times the relay will control the lights to go out [5].

Previous studies have been used as a reference in making an arduino-based light control system, the difference between this light control system and the reference mentioned earlier is in this study using Ethernet Shield and Wifi Router as data transfer and connecting between Arduino microcontrollers and Android smartphones. By looking at the existing references, it is expected that this light control system research can make it easier for everyone to turn on or turn off the house lights without having to use a switch.

3.0 RESEARCH METHODOLOGY

This Android-based light control system construction uses tools that are 1). Hardware: Arduino Microcontroller, Relay, Ethernet Shield, Wifi Router. 2). Software: C programming

language, and Arduino IDE. The system construction involves two stages, namely the assembly of tools and making coding through the Arduino IDE to connect and run the series of systems. The steps in making the application system can be seen in Figure 1.

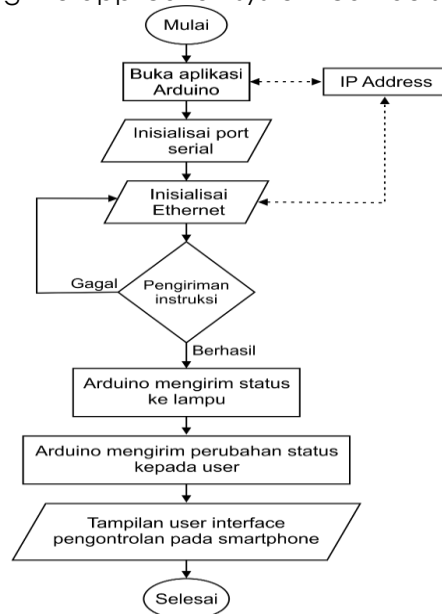

Figure 1. Steps of making the system

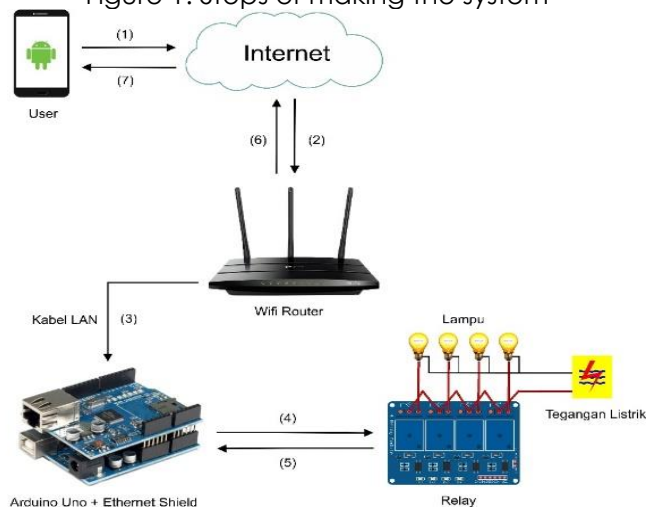

Figure 2, Android-based Light Control Application System Architecture

The flow process of how the Android-based light control application system works can be seen in Figure 2. The instructions sent and received by the user and microcontroller utilize the internet network. In the microcontroller connected to Ethernet Shield that is connected to the Router that supports the microcontroller can function as a connecting bridge in sending and receiving instructions between the user and the microcontroller. The next process is that the microcontroller receives instructions sent by the user and then checked whether it is suitable or not. After adjusting then the microcontroller sends commands to the lamp objects on the system. When the instruction has been carried out on the equipment, then the condition status of the application changes according to the instructions made by the user.

The system works as follows:

1. The user is connected to the internet using an Android Smartphone to give a command to turn on or turn off the lamp.
2. The router must be connected to the internet so that the entire system can communicate properly. The router functions as an internet network source for microcontroller devices that will send and receive instructions from the user.

3. Ethernet Shield is connected to the Router via a LAN cable so that the microcontroller gets the internet network.
4. Arduino UNO is tasked executing incoming instructions and then sending instructions to the Relay so that the lights can turn on or off.
5. When the lamp is in accordance with the command, the lamp will provide feedback response to the condition of the lamp, whether the lamp is on or off.
6. The response from the lamp is read by the Arduino which is connected to the Ethernet Shield to be sent to the user.
7. The user receives a response in the form of status from the light state.

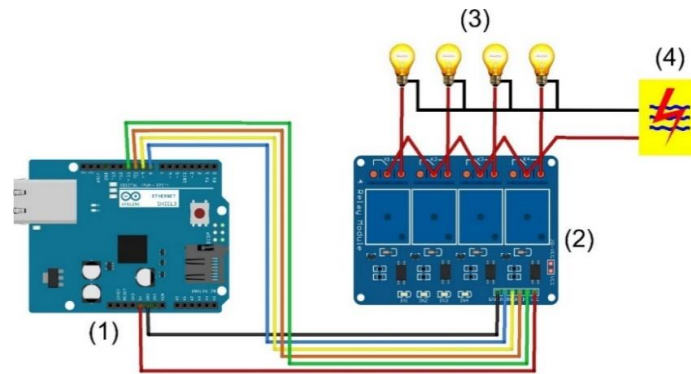

Figure 3: Component Series Design

In the system that will be made there is a series of systems and several components so that the system can run well. The design of the system design is shown in Figure 3. In Figure 3, Number 1 is an Ethernet Shield that is connected via a jumper cable with Relay number 3. Relay has 6 pins, namely: GND, IN1, IN2, IN3, IN4, and VCC that is connected to Ethernet Shield. The ground on the Relay is shown by a black cable connected to the Ground in the Ethernet Shield. IN1 is connected to pin 8 on the Ethernet Shield connected to the blue cable. IN2 is connected to pin 9 on the Ethernet Shield connected by a yellow cable. IN3 is connected to pin 10 on an Ethernet shield connected to a red cable. IN4 is connected with pin 11 on the Ethernet Shield connected to the green cable. Then the VCC on the Relay is connected to the 5V pin on the Ethernet Shield connected to the red cable. Number 3 is a lamp with a 5 Watt voltage that functions as an indicator object on the system. In number 4 shows that in the circuit the system is connected with electric current.

4.0 DISCUSSION

The design results of the tool are made in the form of a miniature light control system measuring 20 cm x 20 cm, with a total of 4 lamps. The main circuit consists of Relay Control, Arduino UNO and Ethernet Shiled. Display design of the light control system is shown in Figure 4.

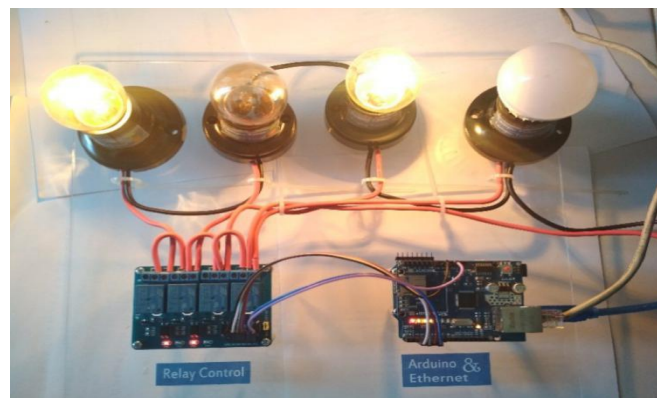

Figure 4: Display of the Light Control System

In order for the system to work, it needs help with light control applications from an Android Smartphone. The user must install the light control app. With the application, users can easily control the lights or the lights. In addition, users can also monitor which lights are on or off. The user must first connect to the internet network on the available router to use this application. Then the user can turn on or turn off the light by pressing the button on the application. The button consists of 4 room lights including KITCHEN LIGHTS, TERM LIGHTS, LIVING ROOMS, and SLEEP LIGHTS. The display of the light control system interface on the smartphone can be seen in Figure 5. The overall application system circuit is shown in Figure 6 which is the overall system design to build the arduino microcontroller-based home light control system with the help of an Android Smartphone.



Figure 5. Display of the Light Control System Application Interface



Figure 6. Lamp Control System Series

Description:

- | | |
|----------------|-------------------------------|
| 1. Lamp | 4. Control system application |
| 2. Wifi router | 5. Relay Module |
| 3. Laptop | 6. Arduino & Ethernet Shield |

The main procedure for coding a program to create a light control system application that is used in the Arduino IDE starts with initialization.

```
#include <SPI.h>
#include "VirtuinoEthernet_WebServer.h" // library virtuino untuk ethernet shield

byte mac[] = {0xDE, 0xAD, 0xBE, 0xEF, 0xFE, 0xED}; // Set ethernet shield mac address.
IPAddress ip(192, 168, 1, 19); // Menentukan alamat ip address.
//cek gateway ip address terlebih dahulu
VirtuinoEthernet_WebServer virtuino(80); // default port=8000
```

Figure 7. Program Code # 1

In Figure 7 describes "VirtuinoEthernet_WebServer" serves as a library to connect Virtuino with Ethernet Shield. Then check the IP Address first on the wifi router to connect to the Ethernet Shield. After that, determine the port that serves to connect Virtuino.

```
//variables

int storedValue=0;
int counter =0;
long storedTime=0;
int numPins = 4;
int pins[] = { 2, 3, 4, 5 }; //Pin yang terhubung pada relay
```

Figure 8. Program Code # 2

In Figure 8 are the variables used to program on the Arduino IDE. Because the pin on the relay only amounts to 4, the pin is declassified like this "int numPins = 4". "Int pins [] = {2,3,4,5};" is the pin number as the path to connect Ethernet Shield to the relay that will be controlled.

```
void setup()
{
  for (int i = 0; i < numPins; i++)
  {
    pinMode(pins[i], OUTPUT);
    digitalWrite(pins[i], 1);
  }

  virtuino.DEBUG=true;
  Serial.begin(9600);
  Ethernet.begin(mac, ip);
  Serial.print("server is at ");
  Serial.println(Ethernet.localIP());

  virtuino.password="1234"; // Set password pada webserver untuk terhubung k virtuino

  pinMode(2,OUTPUT);
  pinMode(3,OUTPUT);
  pinMode(4,OUTPUT);
  pinMode(5,OUTPUT);
}
```

Figure 9. Program Code # 3

The program code "Serial.begin (9600)" in Figure 9 serves to adjust the speed of sending the program from the PC to Arduino Uno. When the program "Serial.println (Ethernet.LocalIP ())", it will appear on the monitor serial IP Address Addres used in Ethernet Shield. The Program code "virtuino.password =" 1234 "functions as an Ethernet Shield security that will connect to Virtuino. The program code "pinmode (2, output);" is the pin that is used as the output of the relay connected to the Ethernet Shield.

```
void loop() {

  virtuino.run(); // command untuk berkomunikasi dg Virtuino android app
  int v=virtuino.vDigitalMemoryRead(0); // Read virtual memory 0 from Virtuino app

  if (v!=storedValue)
  {
    Serial.println("-----Virtual pin DV0 is changed to="+String(v));

    if (v==1) digitalWrite(2,1);
    else digitalWrite(2,0);
    if (v==1) digitalWrite(3,1);
    else digitalWrite(3,0);
    if (v==1) digitalWrite(4,1);
    else digitalWrite(4,0);
    if (v==1) digitalWrite(5,1);
    else digitalWrite(5,0);
    storedValue=v;
  }
}
```

Figure 10. Program Code # 4

In Figure 10 is the main program code to run this light control system. In this code functions as a regulator of lights for life or death. Code 1 means the lamp is on and code 0

shows that the lamp is off. In the program code "if (v = 1) digitalWrite (2,1); else digitalWrite (2,0);" is a program if the pin on number 2 is equal to 1 then the light will turn on. Conversely if the pin on number 2 is equal to 0 or not equal to 1 then the lamp will be conditioned to die. When the program is uploaded, a serial monitor will appear on the Arduino IDE that displays the IP Address that is connected to the router with an Ethernet shield on this system. As shown in Figure 11.

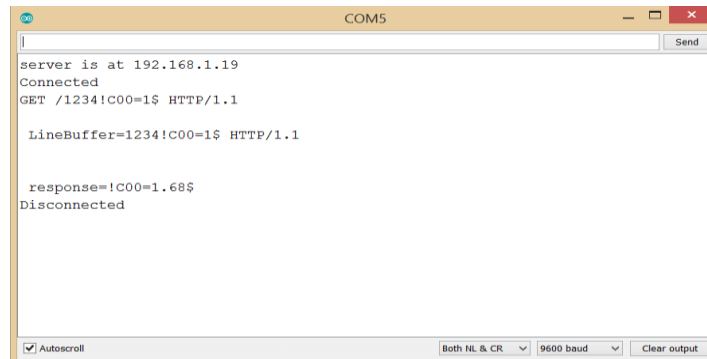

Figure 11: Serial Monitor Display

In designing a light control system, various tools are needed, namely Arduino Uno Microcontroller, Ethernet Shield, Relay Module, 4 sets of lights, jumper cable. The relay can be connected with Ethernet Shield must use 5V power. Ethernet Shield serves as a liaison between the Arduino microcontroller and the smartphone to give commands to the relay in the form of a light or dead condition on the lamp.

Testing of the distance and time needed to access lights

The test of each lamp is carried out as many as 4 times of execution with different distances. This test is done to determine the distance of the system range and the system response time needed to execute each lamp. Test results can be seen in Table 1.

Table IV.2. Distance and Time Testing Results

Lamp	Initial circumstances	Final situation	Distance (Meter)	Time (seconds)	Results
1	OFF	ON	5	0.8	success
			15	0.9	success
			30	-	failed
	ON	OFF	5	0.8	success
			15	0.8	success
			30	-	failed
2	OFF	ON	5	0.6	success
			15	0.9	success
			30	-	failed
	ON	OFF	5	0.8	success
			15	1.1	success
			30	-	failed
3	OFF	ON	5	0.7	success
			15	0.9	success
			30	-	failed
	ON	OFF	5	0.9	success
			15	1.2	success
			30	-	failed
4	OFF	ON	5	0.8	success
			15	1.1	success
			30	-	failed
	ON	OFF	5	0.7	success
			15	1.2	success
			30	-	failed

The test results obtained the fastest execution time to turn on the light and turn off the lamp for 0.6 seconds, occurred in testing the lamp 2 with a distance of 5 meters, which is possible because the network condition is not busy so the reading of the Ethernet Shield is continued to Arduino Uno is then executed to the lamp faster. While the longest access time is 1.2 seconds at the execution of lights 3 and 4 at a distance of 15 meters. In the test the 30 meter range of the system failed so the system could not work. This can occur because an Android Smartphone is outside the range of the wifi beam from the router, so the wifi connection will be automatically disconnected and the light control system will not be accessible. The difference in execution time in the use of this system can be caused by the wifi distance and network conditions that are experiencing interference. Besides that, the wifi barrier can also affect the delay time when executing lights. So as to allow failure and the difference in execution time in the use of this light control system. As technology develops, today most people depend on smartphones. With the Smartphone every thing can be done easily. Therefore, it is expected that with this light control system.

5.0 CONCLUSION

Based on the results of the research that has been done, it can be concluded several things, including:

1. Users can access the application system via Smartphone as a medium to control home lights remotely without having to use a light switch.
2. In testing this light control system, the shortest execution time response occurred in the 2 lamp test with a distance of 5 meters by 0.6 seconds and the longest execution time occurred at 3 and 4 lamp testing with a distance of 15 meters at 1.2 seconds. At a distance of 30 meters the system is not accessed due to outside the wifi range.
3. Network conditions and wifi coverage distance determine the success and execution time in sending commands to the lights.
4. Control of the light control system will fail to be executed when the long distance of the smartphone with wifi is outside the range.
5. Communication between an Android Smartphone with an Arduino Uno microcontroller can be done wirelessly using Ethernet Shield, where an Android Smartphone and Ethernet Shield on a microcontroller system can communicate using an IP Address.
6. Ethernet Shield works well as a command receiving device when connected to an internet connection.

Suggestions

This system cannot be separated from advantages and disadvantages. Therefore, the researcher gives several suggestions that can be used as a reference in further development research, as follows:

1. Create a system to adjust the brightness level of the lamp.
2. Add a timer feature so that the lights can be set for how long the lamp is on.
3. Adding MCB (Miniature Circuit Breaker) to the system so that the system has protection in electrical installations if there is more load and a short circuit of electrical current.

Acknowledgment

Thanks are conveyed to the AKPRIND Yogyakarta Institute of Science & Technology for providing funding and facilities for research on the Arduino Home Light Control Application with Mobile-Based Wifi Media, so that the implementation of this research went well.

REFERENCES

- [1] Oktaviani, T. W. (2014). Perancangan User Interface Berbasis Web untuk Home Automation, <http://ejnteti.jteti.ugm.ac.id/index.php/JNETI/article/view/85>

- [2] Guntoro, H., Sumantri, Y., & Haritman, E. (2013). Rancang Bangun Magnetic Door Lock Menggunakan Keypad Solenoid Berbasis Mikrokontroler Arduino Uno. *Electrans Vol 12*, 39-48.
- [3] Setiawan, E. T. (2015). Pengendalian Lampu Rumah Berbasis Mikrokontroler Arduino Menggunakan Smartphone Android. *Teknik Informatika STMIK ATMA LUHUR PANGKALPINANG*, <https://lppm.atmaluhur.ac.id/>
- [4] Risanty, R. D., & Arianto, L. (2016). Rancang Bangun Sistem Pengendalian Listrik Ruangan dengan Menggunakan ATMEGA 328 dan SMS Gateway Sebagai Media Informasi, <https://jurnal.umj.ac.id/index.php/just-it/article>
- [5] Mochtiarsa, Y., & B. S. (2016). Rancangan Kendali Lampu Menggunakan Mikrokontroler ATmega328 Berbasis Sensor Getar, *Jurnal Informatika SIMANTIK*, www.jurnal.stmikcikarang.ac.id/index.php/Simantik/art